



# General Safety

Pathfinders Friends - E-camp 2020





# Today's Session!

- To help the Friends understand and practice simple, general safety standards.

What does the bible say?

- You are my hiding place; you will protect me from trouble and surround me with songs of deliverance. [Psalm 32:7](#) **NIV**



# How quickly can you find these verses



1. [Nahum 1:7](#)

2. [Proverbs 10:9](#)

3. [Proverbs 18:10](#)





# How quickly can you find these verses

- The Lord is good, a refuge in times of trouble. He cares for those who trust in him. [Nahum 1:7](#) | [NIV](#)
- Whoever walks in integrity walks securely, but whoever takes crooked paths will be found out. [Proverbs 10:9](#)
- The name of the Lord is a fortified tower;  
the righteous run to it and are safe. [Proverbs 18:10](#) | [NIV](#) |

# Water Safety

- Presentation

# 1. Find the key words

- Extension – on an additional sheet explain what 5 of these word means.



## Pool Safety

a d s i t f w p s d f l  
s w i m m i n g a i l e  
h a o w p d i l f x o d  
a p o o l r u l e s a a  
l f e l k h d a t f t n  
l e x o i n o t y e a g  
o n u i o m e n g a t e  
w c r k b l s e o y i r  
i e c d e e p i x g o u  
g f t h y j k t m t n s  
n p l i f e g u a r d b  
c h e m i c a l s l k n

swimming	lifeguard	pool rules
floatation	shallow	danger
gate	deep	chemicals
fence	obey	safety

# Answers



## Pool Safety Answers

a d s i t f w p s d f l  
s w i m m i n g a i l e  
h a o w p d i l f x o d  
a p o o l r u l e s a a  
l f e l k h d a t f t n  
l e x o i n o t y e a g  
o n u i o m e n g a t e  
w c r k b l s e o y i r  
i e c d e e p i x g o u  
g f t h y j k t m t n s  
n p l i f e g u a r d b  
e h e m i c a l s l k n

swimming

floatation

gate

fence

lifeguard

shallow

deep

obey

pool rules

danger

chemicals

safety

# Discussion Cards



## Water Safety Discussion Cards

The Royal Life Saving Society UK advises that inflatables are not used in open water but only in enclosed bodies of water such as rock pools.

Talk about why it might be dangerous to use inflatables in open water.

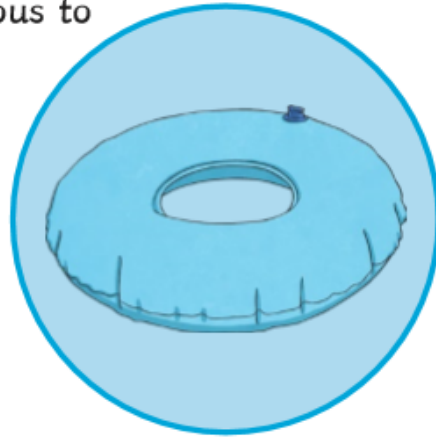

## Water Safety Discussion Cards

The Royal National Lifeboat Institution has released guidance on what to do if you find yourself in difficulty in water. The steps are: to fight your instinct to thrash around; lean back; extend your arms and legs; gently move your arms and legs to help you float; float until you can control your breathing; and only then call for help or swim to safety.

Why do you think calling for help and swimming to safety are the last stages in the guidance?





## 2. Spot the difference!

- Can you spot the difference?



## Pool Safety

There are 8 differences in the pictures below. Can you find them? Circle them in red.



# Answers

## Pool Safety Answers



# 3. Answer the questions

## Pool Safety

slowly	jump on	push
flotation	gate	shallow
lifeguard's	choke	adult

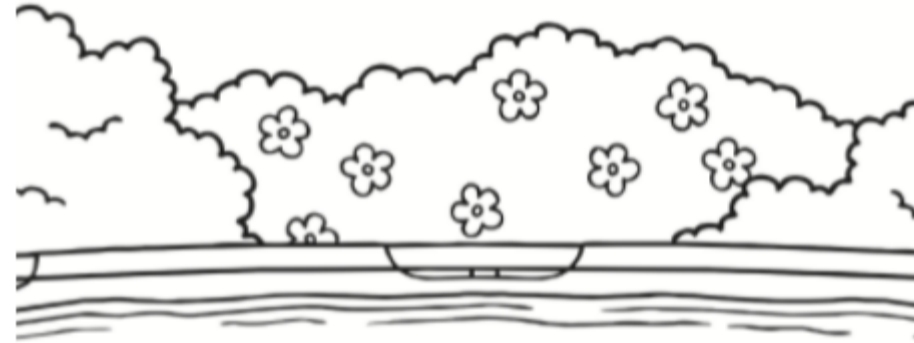

1. Never open the \_\_\_\_\_ or climb the pool fence.
2. Always have an \_\_\_\_\_ with you when you are in the pool.
3. Never jump into the \_\_\_\_\_ end of the pool.
4. Walk \_\_\_\_\_ around the edge of the pool.
5. Wear a \_\_\_\_\_ device if you are not confident.
6. Do not \_\_\_\_\_ people into the pool or \_\_\_\_\_ people in the pool.
7. Do not eat or chew gum in a pool as you could \_\_\_\_\_.
8. Always follow the pool rules and obey the \_\_\_\_\_ directions.





## Pool Safety Answers

1. Never open the **gate** or climb the pool fence.
2. Always have an **adult** with you when you are in the pool.
3. Never jump into the **shallow** end of the pool.
4. Walk **slowly** around the edge of the pool.
5. Wear a **flotation** device if you are not confident.
6. Do not **push** people into the pool or **jump on** people in the pool.
7. Do not eat or chew gum in a pool as you could **choke**.
8. Always follow the pool rules and obey the **lifeguard's** directions.

# 4. Water Safety

- Extended Learning – reflect on your learning on water safety by completing this additional activity On your own.



## Design a Water Safety Poster

Using everything you know about water safety, design a poster telling people how to keep safe in the water. Your poster could be about general water safety or specific to a certain type of water, such as swimming pools or the beach. Decide whether your poster should be aimed at younger children, older children or adults.

A large empty rectangular box for designing a water safety poster.

## An Amazing Fact a Day

### Staying Safe In The Open Water

#### Amazing Fact

In 2014, Australian swimmer Chloe McCardel completed what is believed to be the longest continuous open water swim ever. She swam seventy-eight miles between two islands in the Bahamas in a time of forty-two and half hours.

#### Challenge

Staying safe in the water is crucial when you are swimming in the open water.

What rules can you think of which should be followed?

Design a poster, which would be found at a beach, to display the water safety rules.

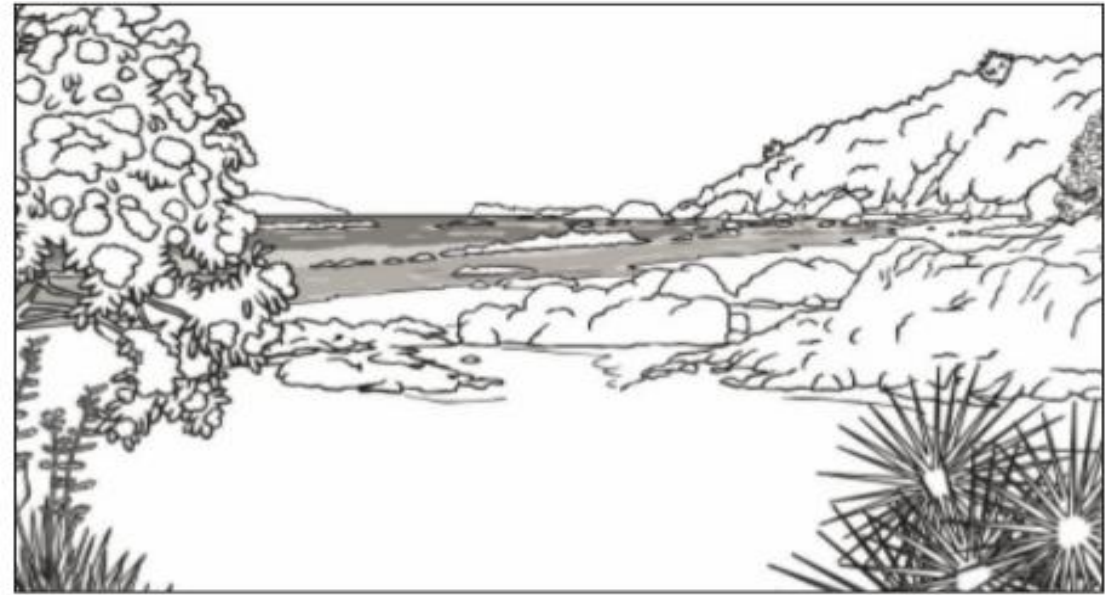

You could also try to find out:

- how long the fastest channel swim took;
- if anyone has swum to France and then back to England;
- what the longest river swim is;
- how long-distance swimmers eat and drink.

# Road and Bicycle Safety



- Road Safety Presentation
- <https://www.youtube.com/watch?v=f7Jrp8Rlzg4>

## The Green Cross Code

Cut out the road safety pictures and then stick them in the correct order for crossing the road safely.

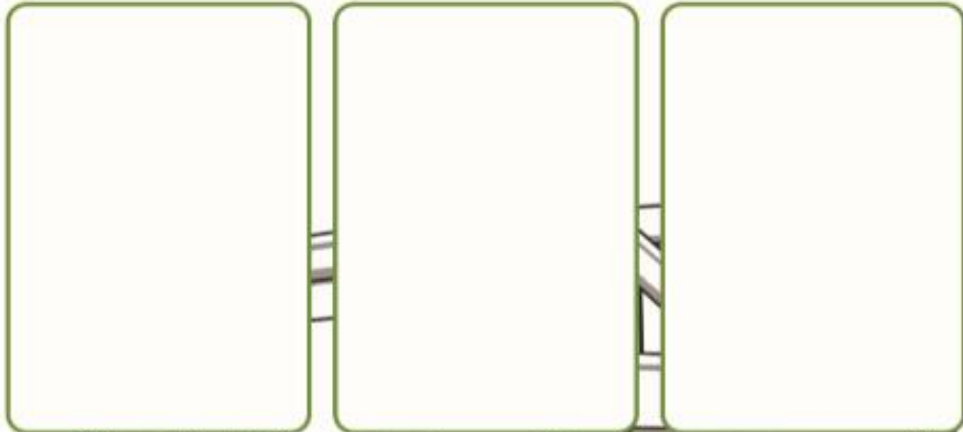

## 5. Sequencing

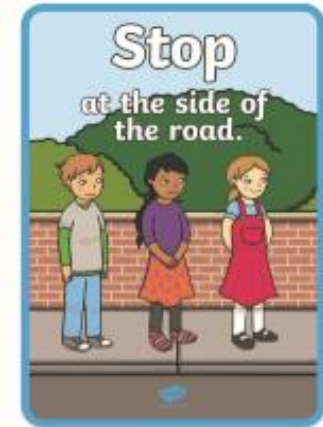
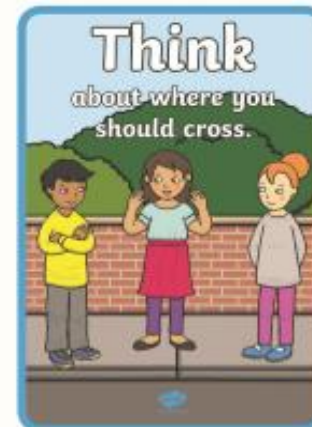
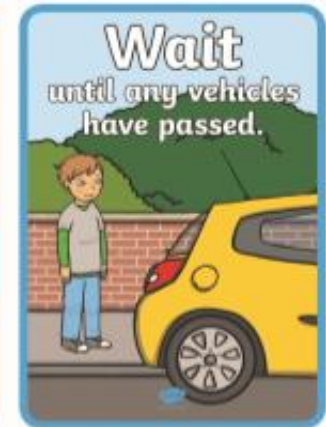

## The Green Cross Code

Cut out the road safety pictures and then stick them in the correct order for crossing the road safely.



--	--	--

--	--	--



## 5. Sequencing

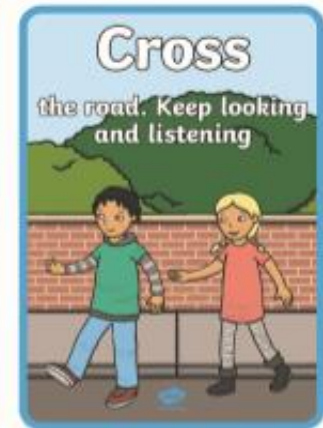
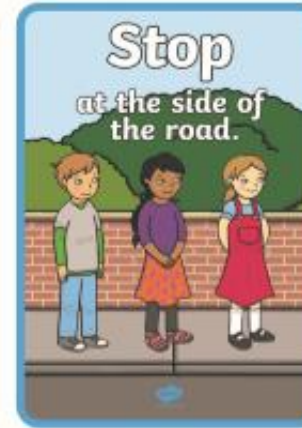
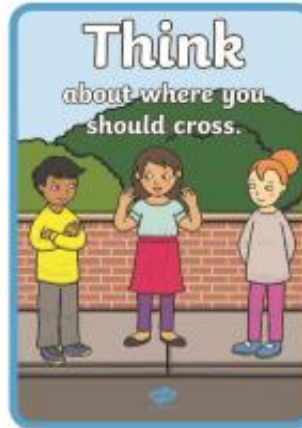



6.



# Question Cards



Road Safety Question Cards

1. What is the crossing guard's job?



Road Safety Question Cards

2. Why is it important to walk in the crosswalk when crossing the street?



Road Safety Question Cards

3. How is the child riding the bicycle being safe?



Road Safety Question Cards

4. What does the red sign which the crossing guard is holding mean?



# Question Cards



Road Safety Question Cards

5. What does the yellow traffic sign tell drivers?



Road Safety Question Cards

6. Why should you wear a helmet when you ride your bicycle?



Road Safety Question Cards

7. Why is the car stopped?



Road Safety Question Cards

8. Why is it safe to walk on the sidewalk?



# Question Cards



Road Safety Question Cards

9. What do you think would happen if you did not walk in the crosswalk?



Road Safety Question Cards

10. What are the three things you should do before you cross the street?



Road Safety Question Cards

11. Why do you have to follow the rules of the road when you ride your bicycle?



Road Safety Question Cards

12. How are the children crossing the street being safe?



# 7. Bicycle Safety – Fill in the gaps

- Complete the sentences using the images as Clues?

Be ready to explain your answer...



## Bike Safety



I always wear a \_\_\_\_\_.



I stop at the \_\_\_\_\_.



I can understand \_\_\_\_\_.

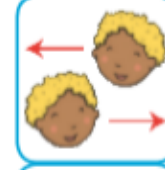

I look both \_\_\_\_\_.



I look out for \_\_\_\_\_.



I look after my \_\_\_\_\_.



In the dark I use \_\_\_\_\_.



# Electricity safety

# 8. Safety in the Home

Sort the images –

- which ones are safe?
- Which ones are unsafe?
- Be ready to explain your answer...



## Safe and Unsafe to Touch Sorting Activity

Safe to touch

Unsafe to touch



# 9. Health Hazards

• Think of your Pathfinder Hall  
Consider why the health hazards  
Listed could cause issues.

1. Broken glass
2. Objects lying around
3. Objects on the wall
4. Fire extinguishers



9. Think of your Pathfinder Hall. Explain the possible Health Hazards

e.g. why should it be fixed? Why is it a problem?

Health Hazard 1: Broken glass

Reason/s:

Health Hazard 2: Objects left lying around.

Reason/s:

Health Hazard 3: Objects on the wall.

Reason/s:

Health Hazard 4: Fire extinguishers

Reason/s:



# 10. Electricity

What Is the Danger?	Who Could Be Affected? Why/How?	What Could You Do to Prevent Harm?



## Reducing Risk – The Safety Inspector



# 11. Matching Activity



Too many fittings to one outlet will cause overheating in the switch or wires. This can lead to fires.

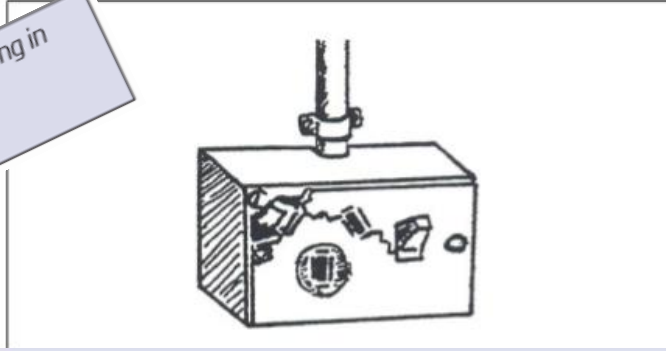

NEVER cut electrical cords with scissors.

Use correct fuse wires. A too heavy fuse wire does not protect the wiring. This can cause a fire.

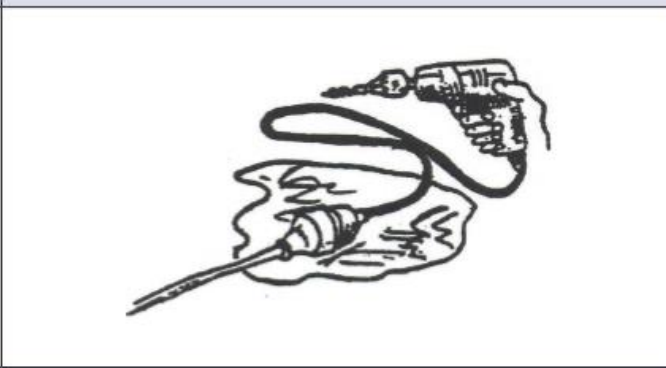
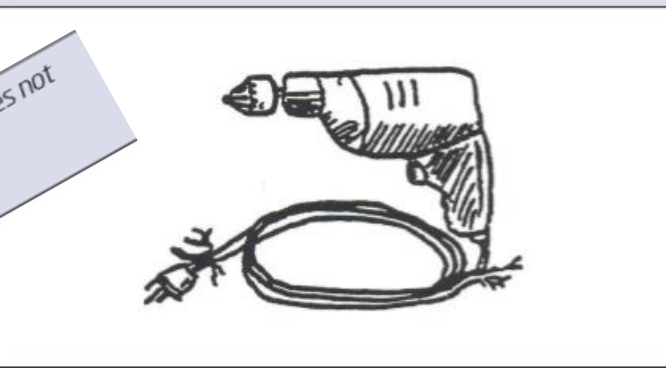

Socket in pool of water.

Do not use damaged plug socket.

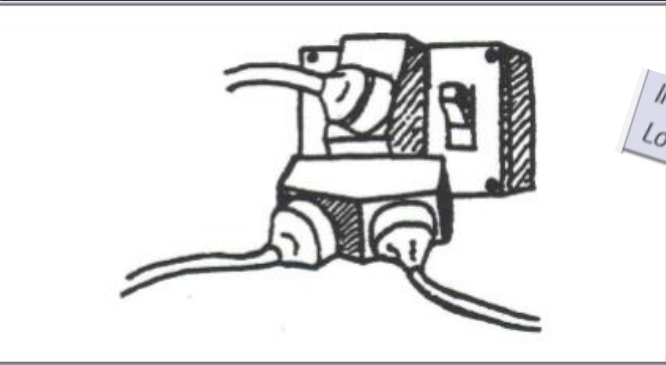
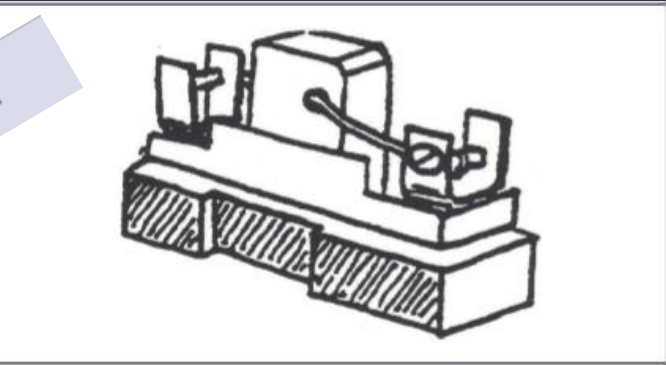

Incorrectly wired plug. Frayed electrical leads or plugs. Loose wires in plug or socket.

# Answers

---

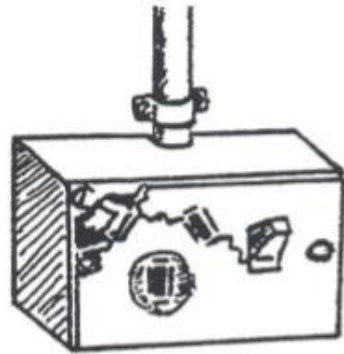

*Do not use damaged plug socket.*



*NEVER cut electrical cords with scissors.*

# Answers

---

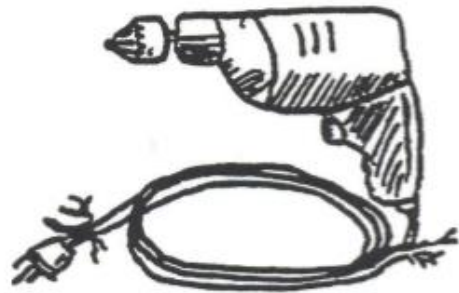

*Incorrectly wired plug. Frayed electrical leads or plugs.  
Loose wires in plug or socket.*



*Socket in pool of water.*

# Answers

---

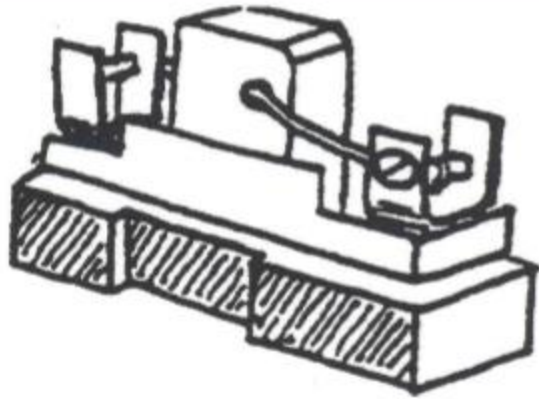

*Use correct fuse wires. A too heavy fuse wire does not protect the wiring.  
This can cause a fire.*

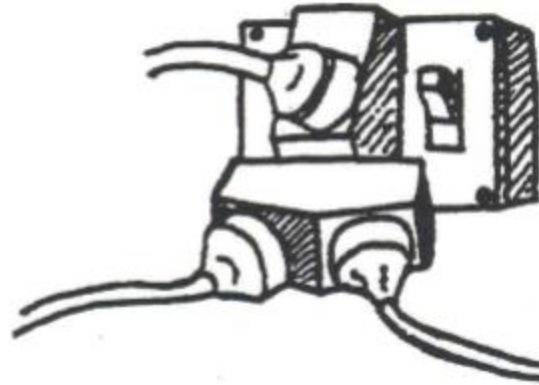

*Too many fittings to one outlet will cause overheating in the switch or wires.  
This can lead to fires.*

# Getting Lost when Camping

---



## 12A. Safety Rules When Lost – Match and Order

---

Mark the spot

Don't try to remember details, but general landmarks. Work out whether it would be better to go on, go back, or stay put.

Climb a Tree or Hill

Kneel down and talk to God. Remember some of His promises: "I am with you always."

Stay Where you are

Build a safe fire. Have enough wood on hand to keep it going all night if required. During the day, once the fire is established, add green leaves to create smoke. Send your own smoke signals.

Light a Fire

Blaze a tree, place a rag on a stick in the ground, or put your hat on a stump.

Sit down and think

From the top you may see a landmark that you recognize. If so, and you are sure which way to go to get you back safely, proceed towards that landmark.

Use your map and compass

You should have a map and compass in your pack-use them. Spread out the map and orient it, either with the compass or by checking the landmarks

Pray

If you are unable to locate a familiar landmark that can lead you home either by sight or by map and compass. Wait for help to come

Give out a distress signal

Distress Signals by Lost Party: Three signals together, regularly spaced.



## 12A. Safety Rules When Lost – Match and Order

Sit down and think

Don't try to remember details, but general landmarks. Work out whether it would be better to go on, go back, or stay put.

Pray

Kneel down and talk to God. Remember some of His promises: "I am with you always."

Stay Where you are

If you are unable to locate a familiar landmark that can lead you home either by sight or by map and compass. Wait for help to come

Climb a Tree or Hill

From the top you may see a landmark that you recognize. If so, and you are sure which way to go to get you back safely, proceed towards that landmark.

Mark the spot

Blaze a tree, place a rag on a stick in the ground, or put your hat on a stump.

Use your map and compass

You should have a map and compass in your pack-use them. Spread out the map and orient it, either with the compass or by checking the landmarks

Light a Fire

Build a safe fire. Have enough wood on hand to keep it going all night if required. During the day, once the fire is established, add green leaves to create smoke. Send your own smoke signals.

Give out a distress signal

Distress Signals by Lost Party: Three signals together, regularly spaced.





## 12B. Pathfinder Club Hall Safety

1. Close your eyes and think about your **club hall/area** for a minute.
2. Are there any Health **hazards** that need to be addressed?
3. Create an informative poster that can remind you and the other pathfinders and adventurers about **good safety rules**.

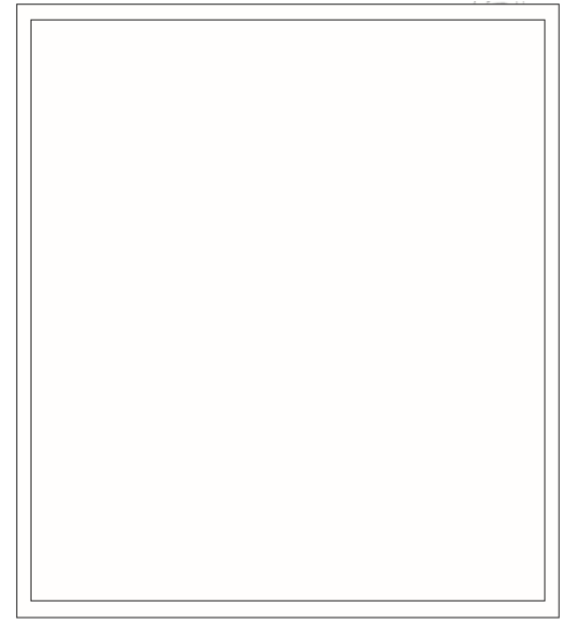

# General Safety Test

Please click on the link on the chat window.

- <https://forms.gle/NTBJeCKmym5jeKiS8>

1. Type in your name
2. Type in your surname
3. Type in your email address
4. Choose your club
5. Carefully answer all the questions
6. CLICK on the SUBMIT button once you are done.

## Area 8 Pathfinder - Friend Class - General Safety Test

Please complete this test after going through the activities in the General Safety-Workbook for the Friend class.

\* Required

Email address \*

Your email

First name \*

Your answer

Surname \*

Your answer

Choose your club (If your club is not listed please select GUEST) \*

Basildon

Braintree